

“How do I add finishes to...”

Cabana

Select your desired Cabana unit from the mediatechnologies Cabana Price sheet by model number.

Follow the Step-by-Step method to tell us how you want your Cabana unit finished. Make sure you indicate your finish choice for each step below in your purchase order. We will list your choices as notes below each individual model number in your order acknowledgement.

To the right is a simple explanation of a mediatechnologies Cabana model number.

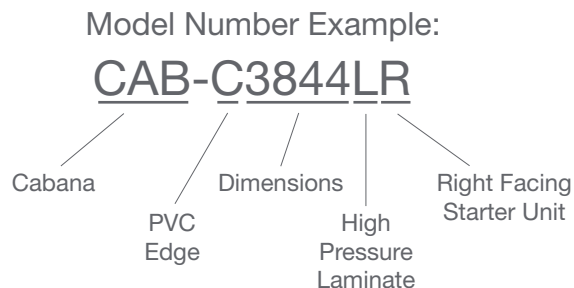

Step 1: Select high pressure laminate for work surfaces, where applicable.

Choose from our selection of finishes.

See our finish selection

<https://www.mediatechnologies.com/resources/finishes>

Enter your selection on the “Work Surface HPL” line on the last page of this designator.

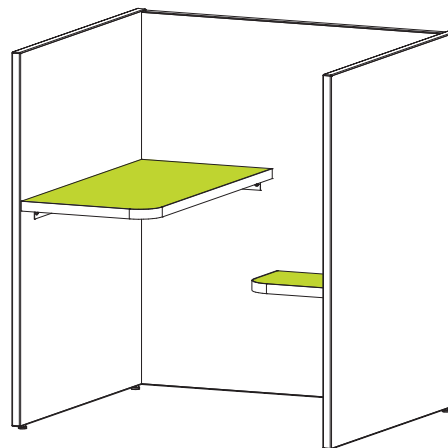

Step 2: Select PVC for work surfaces, where applicable.

Choose from our selection of finishes.

See our finish selection

<https://www.mediatechnologies.com/resources/finishes>

Enter your selection on the “Work Surface PVC” line on the last page of this designator.

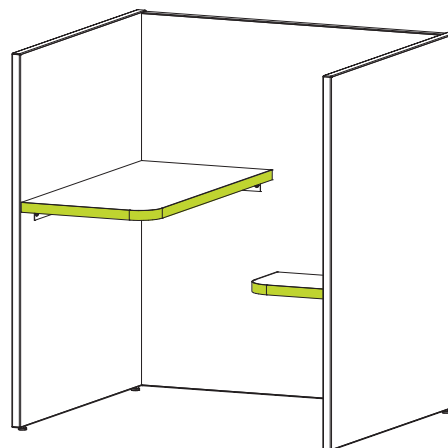

“How do I add finishes to...”

Cabana

Step 3: Select high pressure laminate for back, end and intermediate panels, where applicable.

Choose from our selection of finishes.

See our finish selection

<https://www.mediatechnologies.com/resources/finishes>

Enter your selection on the “Panel HPL” line on the last page of this designator.

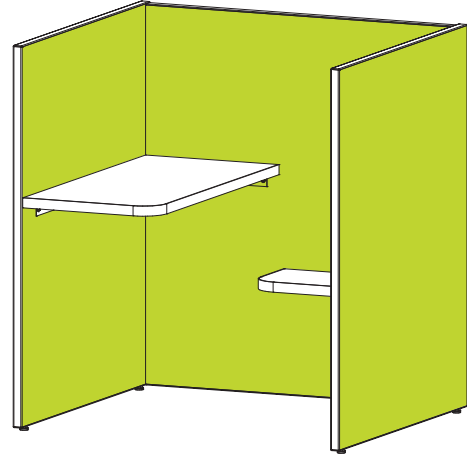

Step 4: If desired, you may designate markerboard finish for the outside of the back panel. If not applicable, back panel will match side panels and you can skip to Step 5.

See our markerboard option at

<https://www.mediatechnologies.com/resources/finishes/laminates>

Enter your selection on the “Markerboard Exterior Back Panel” line on the last page of this designator.

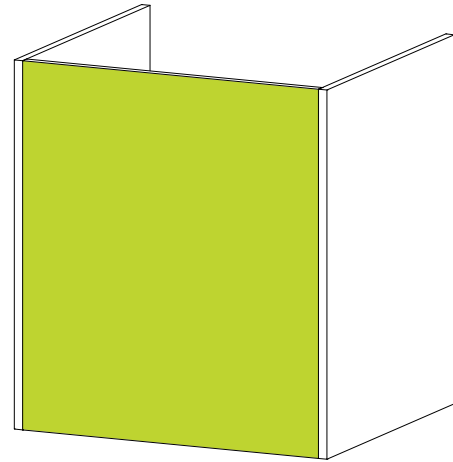

Step 5: Select PVC for all panel edges.

Choose from our selection of finishes.

See our finish selection

<https://www.mediatechnologies.com/resources/finishes>

Enter your selection on the “Panel Edge PVC” line on the last page of this designator.

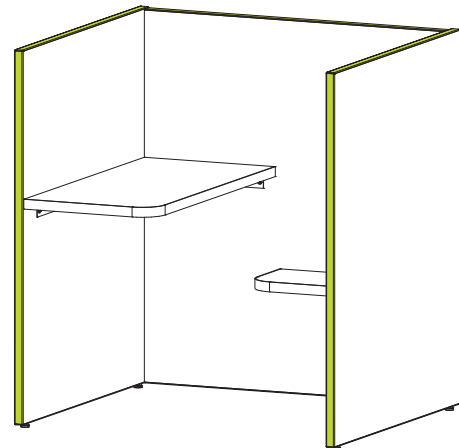

“How do I add finishes to...”

Cabana

Step 6 (for double wide units ONLY):

For double wide units, markerboard is also an option for the interior side of the back panel. If applicable, select markerboard for interior double wide back panel.

See our markerboard option at

<https://www.mediatechnologies.com/resources/finishes/laminates>

Enter your selection on the “Interior Back Panel” line on the last page of this designator.

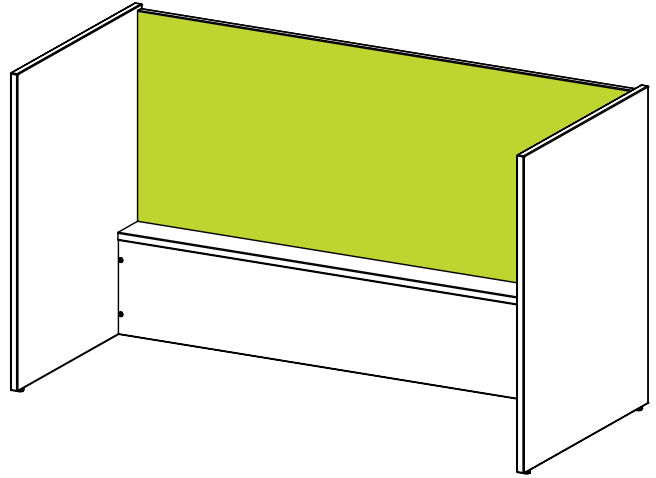

Note: Double Wide Double Faced units will receive markerboard on all interior back panels if this option is selected.

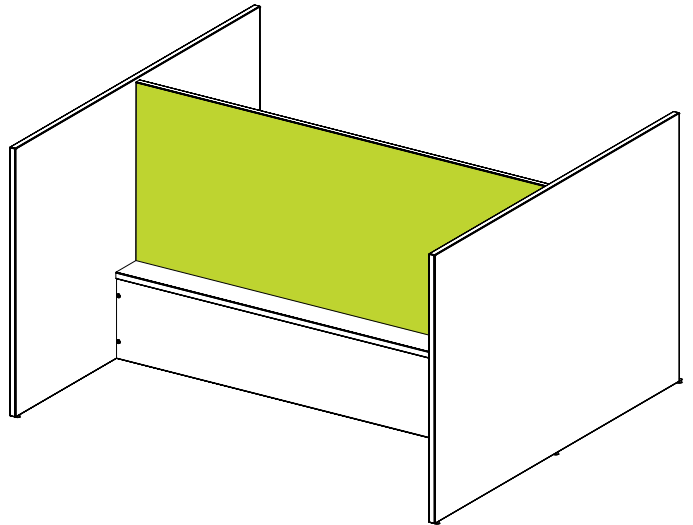

“How do I add finishes to...”

Cabana

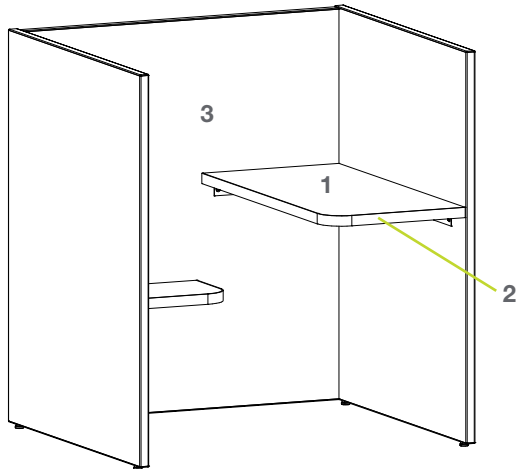

CAB-3844LL

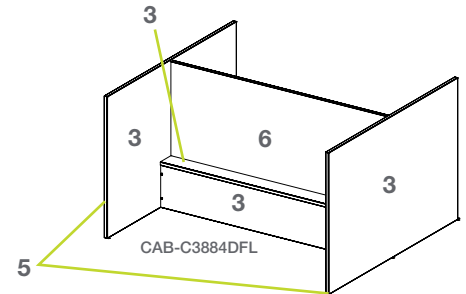
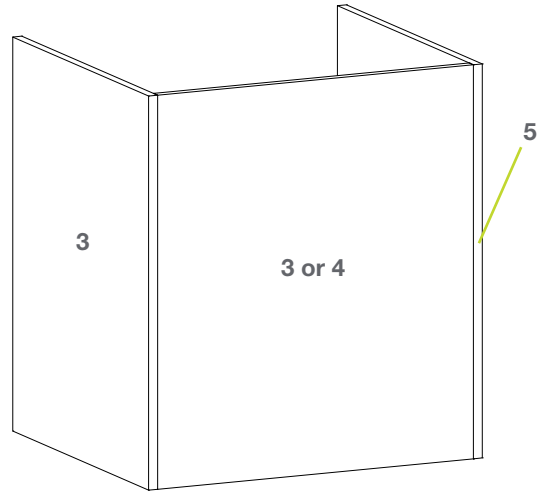

Job:
Model Number:
Finish Schedule:

1 Work Surface HPL: _____

2 Work Surface PVC: _____

3 Panel HPL: _____

4 Markerboard Exterior Back Panel, if applicable: _____

5 PVC Panel Edges: _____

6 Interior Back Panel Markerboard, if applicable: _____