

Cirrus Computer

Tables

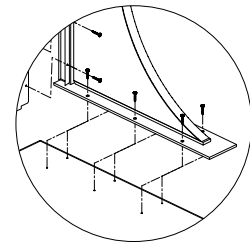

Leg Frame and Table Top

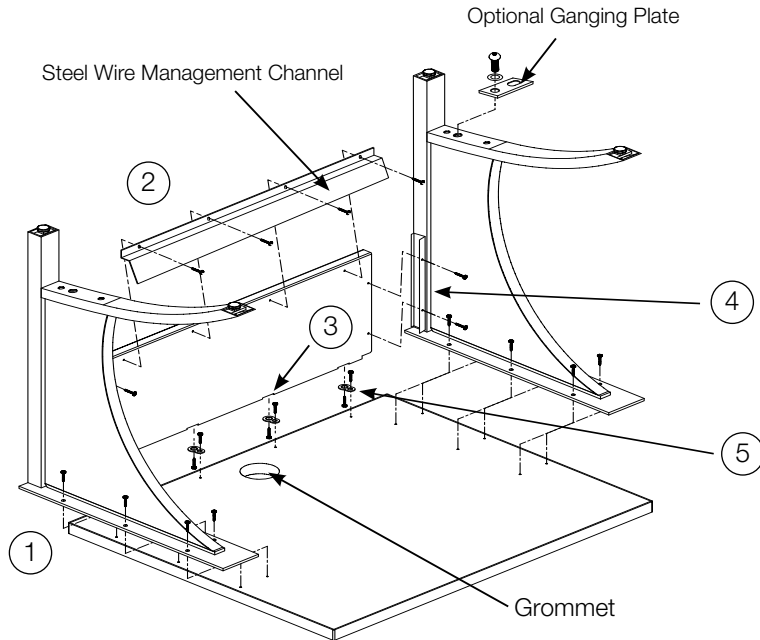
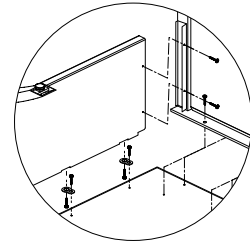

Veneer Modesty Panel

Hardware Included:

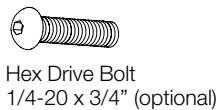
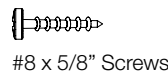
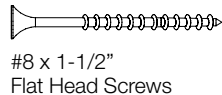
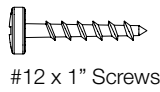

Tools Required:

- #2 Phillips Head Screwdriver or #2 Square Drive
- #3 Phillips Head Screwdriver

Step 1: To attach leg frame assemblies to the table top, place the top upside down on a clean padded surface. Locate the steel leg frame assemblies on to the table top above the machined locations. The U-channel that is fixed to the front post of each leg faces to the inside (one is right-facing and one is left-facing). Attach legs to the top using (6) #12 x 1" PH screws per leg. **DO NOT TIGHTEN.**

Note: Your leg frame assemblies may be provided with wire management holes required for your layout. Please note these leg frame assembly positions and attach them to the table top according to your layout.

Step 2: To attach the wire management channel place the modesty panel face down on a clean padded surface. Align the holes in the bottom mounting face of the wire management channel with the pre-drilled holes near the bottom of the inside face of the modesty panel. When aligned correctly, the open area of the channel should be facing in the same direction as the top of the modesty panel. Attach and secure the wire management channel to the modesty panel with #8 x 5/8" PH screws.

Step 3: To insert modesty panel into leg frames, flip the modesty panel up (top edge facing you). Place the large end of a figure-8 fastener into each pocket location along the top edge of the modesty panel (counter sunk side up and small loop of the fastener facing in). Attach each figure-8 fastener using a #8 x 1-1/2" FH screw. Screws must be fully inserted. Flip modesty panel upside down and insert (finished side out, figure-8 connectors first and facing in) into the U-channels on the front post of each leg. Do not attach at this point.

Step 4: To fasten modesty panel, adjust leg frames so the u-channels hold the modesty panel securely. Align the machined holes on the inside face of each U-channel with the holes on each end of the modesty panel. Attach the modesty panel to the leg frames with #8 x 5/8" PH screws. Tighten.

Step 5: Secure legs and modesty panel to table top by tightening screws connecting the leg frames to the top. Locate the small end of each figure-8 connector. Attach the modesty panel to the table top using #8 x 5/8" PH screws. Tighten securely. Verify all screws are tightened. Flip table over.

For optional ganging plate: Attach the leg frame assembly to the table top. With table standing on its feet, attach the 1" x 6" steel ganging plate to the bottom of a leg end frame by threading a 1/4-20 x 3/4" HD bolt and 7/8" flat washer through the ganging plate and in to the weld nut located in the bottom of the leg frame, behind the front leg post. Securely tighten the bolt. Move second table into place and align the second table's weld nut with the open hole in the ganging plate. Thread a bolt and washer through the ganging plate into weld nut of the second leg frame and tighten securely.

instructions-cirrus-191126

