

# “How do I add finishes to...”

## Rojon

**Select** your desired Rojon unit from the mediatechnologies Rojon Price Sheet by model number.

**Follow** the Step-by-Step method to tell us how you want your Rojon Unit finished. Make sure you indicate your finish choice for each step below in your purchase order. We will list your choices as notes below each individual model number in your order acknowledgement.

To the right is a simple explanation of a mediatechnologies Rojon model number.

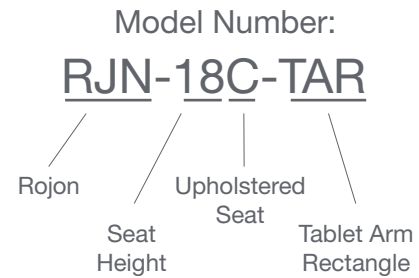

### Step 1: Select fabric for seat cushion.

Choose from our selection of fabrics.  
See our selection of finish choices at <https://www.mediatechnologies.com/resources/fabrics>

Enter your selection on “Seat Fabric” line on the last page of this designator.

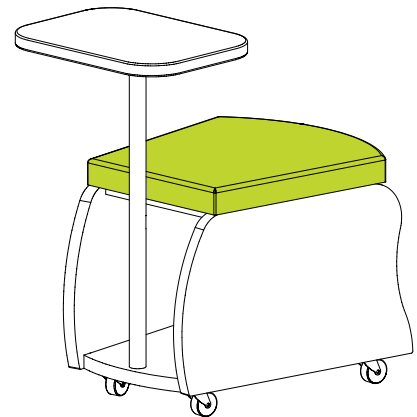

### Step 2: Select high pressure laminate for mobile storage base.

Choose from our selection of finishes.  
See our selection of finish choices at <https://www.mediatechnologies.com/resources/finishes>

Enter your selection on “Base HPL High Pressure Laminate” line on the last page of this designator.

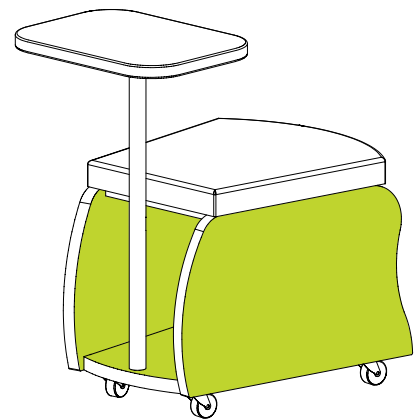

# “How do I add finishes to...”

## Rojon

### Step 3:

Select PVC for mobile storage base.

Choose from our selection of finishes.

See our selection of finish choices at

<https://www.mediatechnologies.com/resources/finishes>

Enter your selection on “Base PVC” line on the last page of this designator.

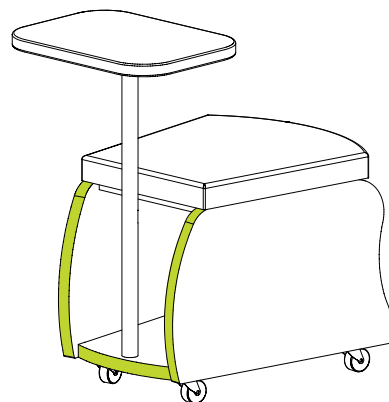

### Step 4:

Select high pressure laminate for tablet worksurface, if applicable.

Choose from our selection of finishes

See our selection of finish choices at

<https://www.mediatechnologies.com/resources/finishes>

Enter your selection on “Worksurface High Pressure Laminate” line on the last page of this designator.

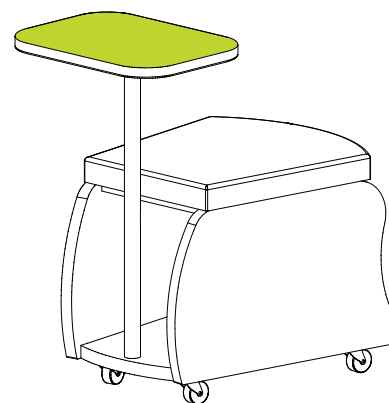

### Step 5:

Select PVC for the tablet worksurface, if applicable.

Choose from our selection of finishes

See our selection of finish choices at

<https://www.mediatechnologies.com/resources/finishes>

Enter your selection on “Worksurface PVC” line on the last page of this designator.

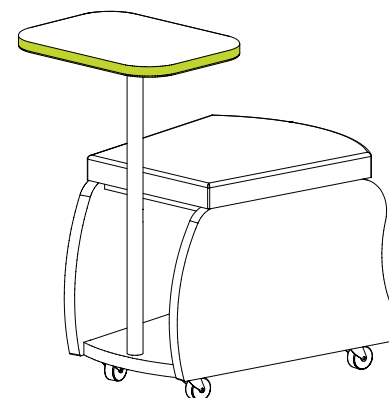

# “How do I add finishes to...”

## Rojon

### Step 6:

Select powder coat for tablet arm, if applicable.

Choose from our selection of finishes.

See our selection of finish choices at

<https://www.mediatechnologies.com/resources/finishes>

Enter your selection on “Tablet Arm Powder Coat” line on the last page of this designator.

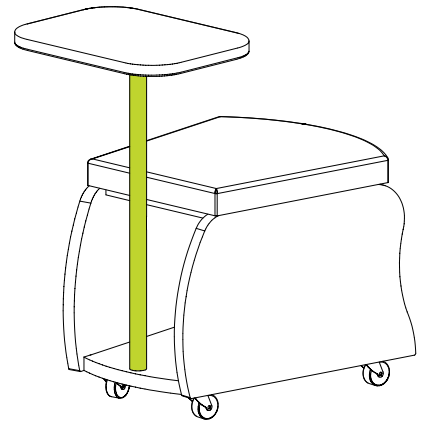

# “How do I add finishes to...”

## Rojon

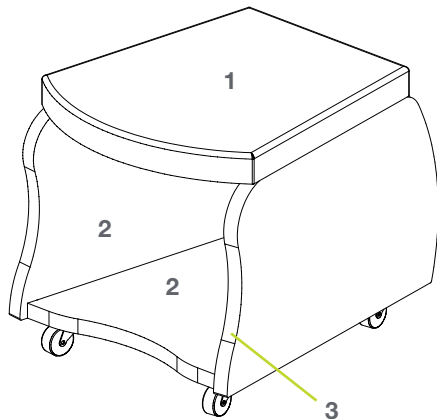

RJN-18C

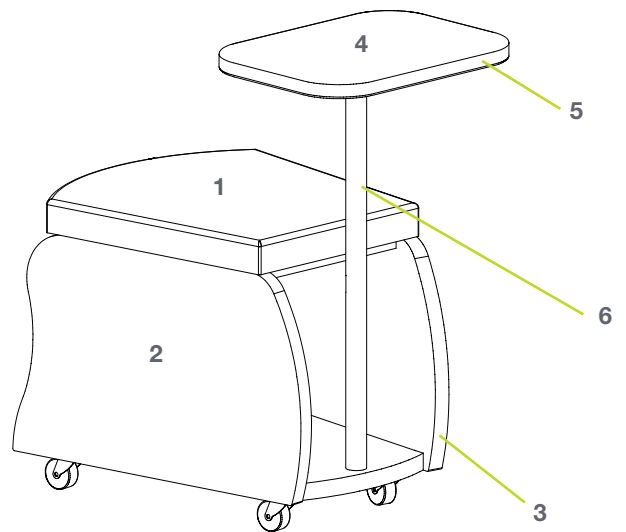

RJN-18C-TAR

Job:

Model Number:

Finish Schedule:

**1** Seat Fabric: \_\_\_\_\_

**2** Base High Pressure Laminate: \_\_\_\_\_

**3** Base PVC: \_\_\_\_\_

**4** Worksurface High Pressure Laminate, if applicable: \_\_\_\_\_

**5** Worksurface PVC, if applicable: \_\_\_\_\_

**6** Tablet Arm Powder Coat, if applicable: \_\_\_\_\_